

INSTALLATION INSTRUCTIONS FOR FIVE HOLE JUNCTION BOX
U.S. PAT No.5,382,752 & 5,541,363

- A.)** RUN CONDUIT TO DESIRED LOCATION FOR JUNCTION BOX HOOK-UP. BOX TO BE LOCATED A MINIMUM DISTANCE OF 48 INCHES MEASURED HORIZONTALLY FROM THE INSIDE WALL OF THE POOL AND NOT LESS THAN 8 INCHES ABOVE THE MAXIMUM POOL WATER LEVEL MEASURED TO THE TOP FACE OF THE JUNCTION BOX BASE. (SEE FIG. #1)
- B.)** SOLVENT WELD JUNCTION BOX BASE TO HEAVY WALL CONDUIT.
- C.)** PULL LIGHT CORDS FROM NICHES AND WIRES FROM PANEL TO THE BOX AND MAKE CONNECTIONS AS REQUIRED. THIS BOX CONTAINS SEVEN GROUNDING TERMINALS PLUS A #8 SPLIT BOLT FOR ADDITIONAL CONNECTION. ALSO, CONNECTED TO THE EXTERIOR OF THE BOX IS A BONDING LUG FOR EXTERNAL BONDING WHERE PERMITTED.
- D.)** ALL CONDUIT HUB OPENINGS HAVE BEEN PROVIDED WITH A STRAIN RELIEF NESTING BLOCK. PLACE CORD INTO STRAIN RELIEF BLOCK. PLACE STRAIN RELIEF CLAMP OVER CORD, ALIGNING MOUNTING-HOLES. INSERT SELF TAPPING SCREWS AND TIGHTEN EVENLY. PUTTING EQUAL PRESSURE ON EACH SCREW. TIGHTEN UNTIL CLAMP BOTTOMS ON NESTING BLOCK. ALL CLAMPS ARE PRE-SET TO GIVE PROPER SQUEEZE AND HOLD CORD IN PLACE. FOUR STRAIN RELIEF CLAMPS ARE PROVIDED. TWO MARKED (12) TO BE USED WITH TYPE SJT No.12/3 FLEXIBLE CORD AND TWO MARKED (16) TO BE USED WITH TYPE ST No. 16/3 FLEXIBLE CORD. (SEE FIG. #2)
- E.)** SOLVENT WELD ALL CONDUIT OPENINGS NOT BEING USED WITH PLUGS PROVIDED.
- F.)** THIS BOX HAS BEEN DESIGNED TO USE A 3/4 DIAMETER PVC ROD FOR SUPPORT. THE INVERTED PLUG PROVIDED WITH THIS BOX SERVES A DUAL PURPOSE. ONE IS TO SEAL A CONDUIT HUB OPENING AND TWO IS TO PROVIDE A HUB LOCATION FOR A SUPPORT ROD. THE ROD MUST BE SOLVENT WELDED TO THE PLUG TO PROVIDE THE SUPPORT FOR THE BOX. THE SUPPORT ROD IS NOT INCLUDED BUT MAY BE OBTAINED VIA THERMOCRAFT INDUSTRIES, INC.(SEE FIG. #1)
- G.)** APPLY O-RING TO COVER. MOUNT COVER ON JUNCTION BOX BASE. ALIGNING MOUNTING HOLES. INSERT SELF-TAPPING SCREWS AND TIGHTEN UNTIL SECURE.

NOTE TO INSTALLER:

- 1.) ALL INSTALLATIONS SHALL CONFORM WITH ARTICLE 680 OF THE NATIONAL ELECTRICAL CODE AND APPLICABLE CODES.
- 2.) THIS JUNCTION BOX IS NON-METALLIC WITH SLIP SOCKETS FOR SOLVENT WELDING. IT WAS DESIGNED AND APPROVED FOR MULTIPLE FIXTURE INSTALLATION AND COMPLIES WITH SAFETY STANDARD UL 1241.
- 3.) HEAVY WALL CONDUIT IS REQUIRED FOR ABOVE GROUND INSTALLATION. THIS BOX IS DESIGNED WITH FIVE CONDUIT HUBS, TWO 3/4", TWO 1", AND ONE 1/2" FLEXIBILITY WITH REGARD TO CONDUIT SIZING.
- 4.) THIS BOX IS SUITABLE FOR LINE AND LOW VOLTAGE (No. 12 AWG MAX.FOR LIGHT CORD). USE EITHER AWG No. 16/3 CONDUCTOR TYPE ST OR AWG No. 12/3 CONDUCTOR TYPE SJT WATER RESISTANT FLEXIBLE CORD.
- 5.) THIS JUNCTION BOX MUST BE RIGIDLY SUPPORTED AND HAS BEEN DESIGNED TO USE A 3/4" DIAMETER PVC ROD FOR THAT PURPOSE. (SEE FIG. #1)

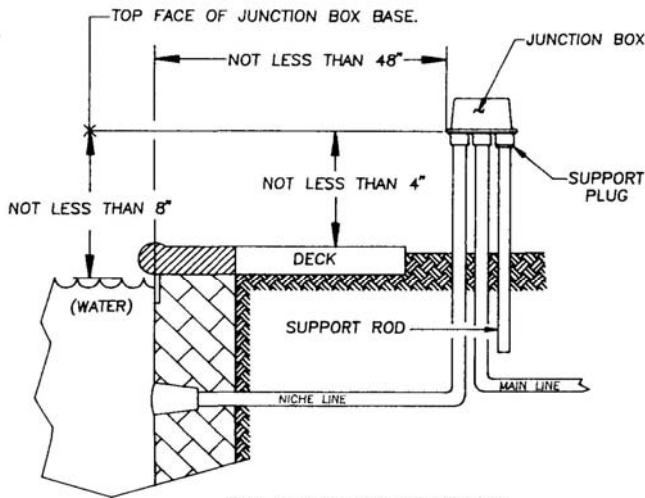

(FIG. #1)

THIS VIEW ILLUSTRATES MINIMUM REQUIREMENTS FOR JUNCTION BOX INSTALLATION, AND 3/4" ROD SUPPORT USING 3/4" ROD PLUG.

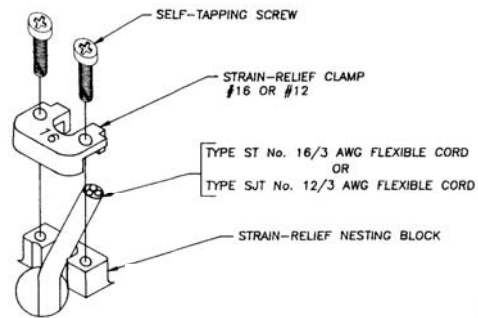

(FIG. #2)



Listed
3Z68

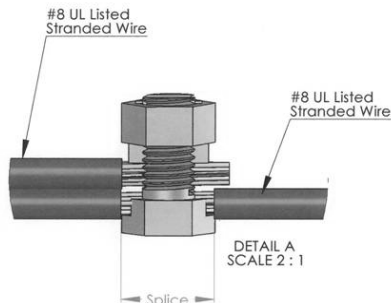

1628 S-8 UL Listed
SB8 Bronze Split Bolt

