

California Codes
Health and Safety Codes
Section 19211

19211. (a) Notwithstanding Section 19100, all new and replacement water heaters, and all existing residential water heaters, shall be braced, anchored, or strapped to resist falling or horizontal displacement due to earthquake motion. At a minimum, any water heater shall be secured in accordance with the California Plumbing Code, or modifications made thereto by a city, county, or city and county pursuant to section 17958.5.

Thermocraft Industries, Inc.
1700 Barcelona Circle
Placentia, Ca. 92870
Ph: 714-792-3899
Fax: 714-792-3844
sales@thermocraftonline.com
www.thermocraftonline.com

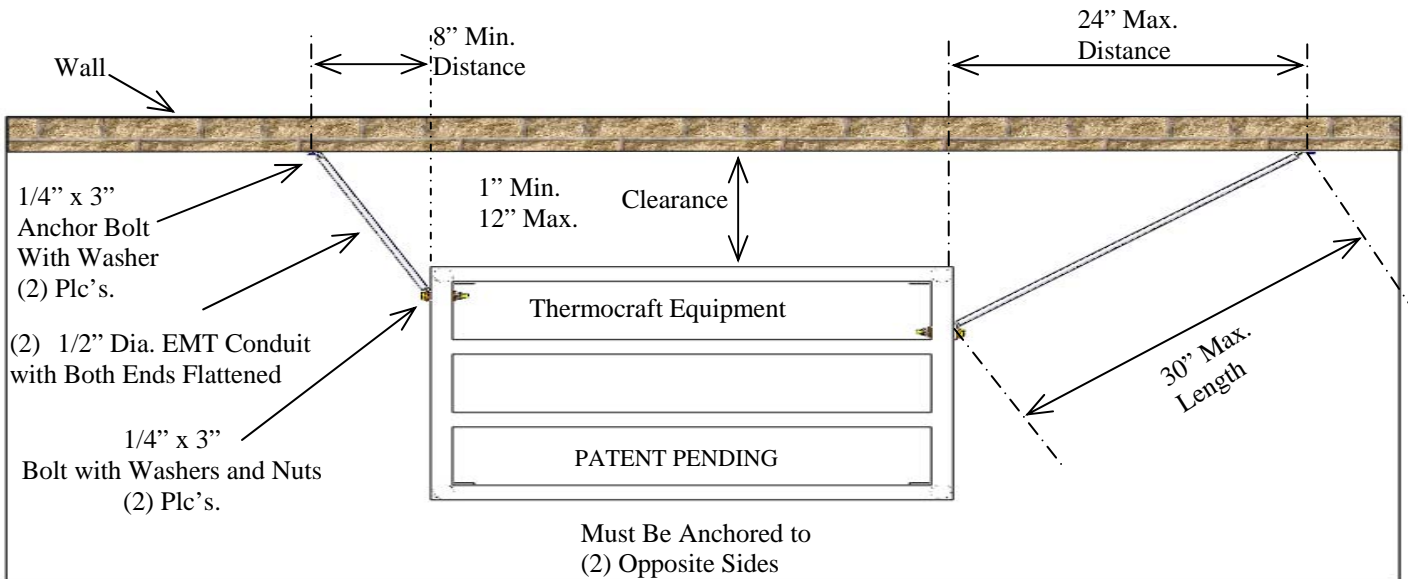
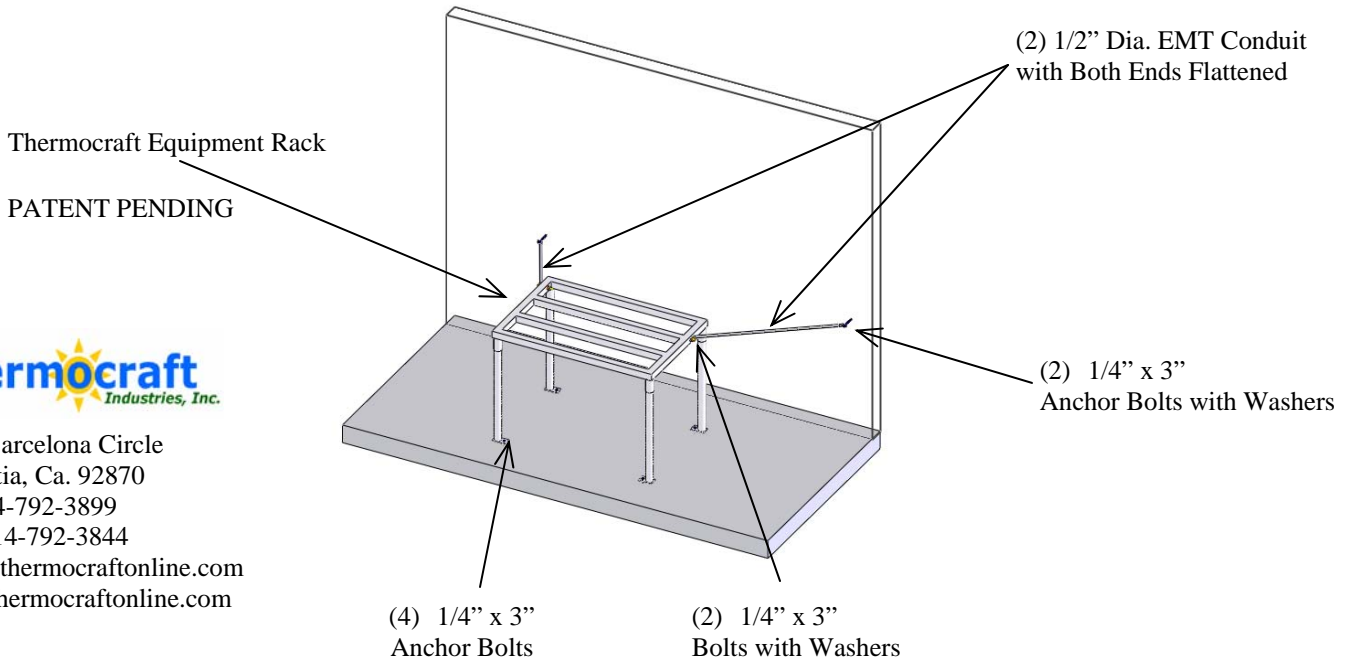

For Further Reference Refer To:
www.oes.ca.gov
www.seismo.unr.edu/ep/example